

PLAN

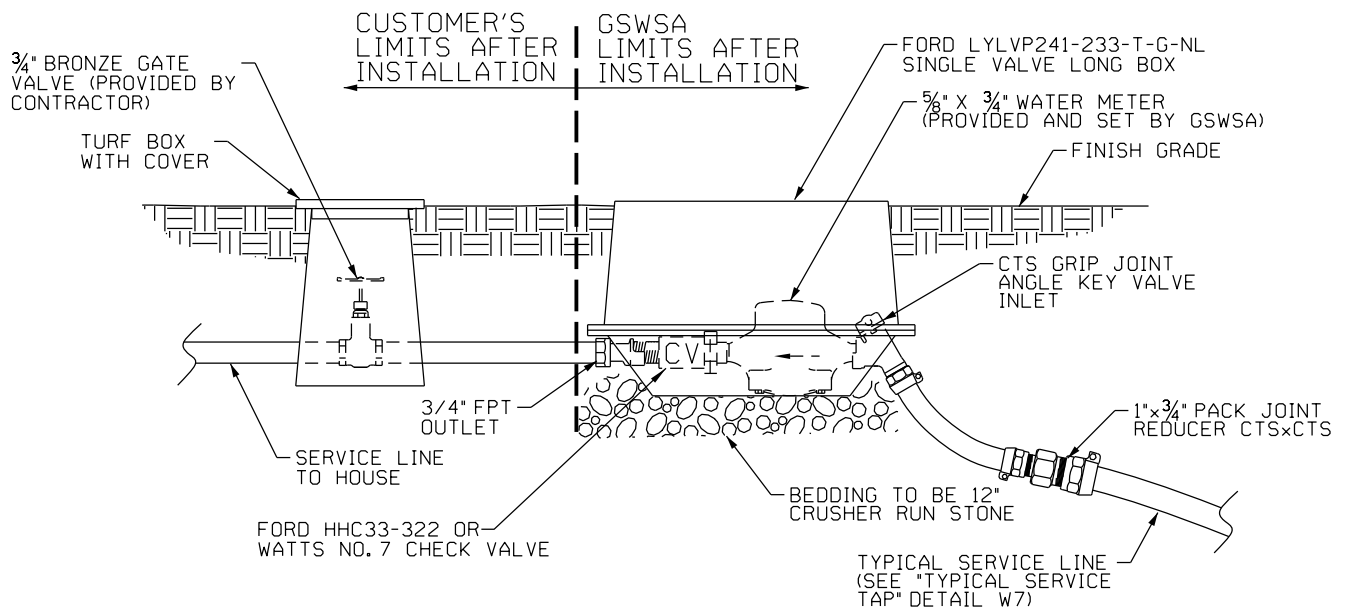

PROFILE

TYPICAL METER BOX 1

W1

TYPICAL WATER SERVICE DETAIL
 FOR FUTURE CUSTOMER CONNECTIONS
 (FOR GSWSA RURAL & CAPITAL
 PROJECTS ONLY)

WATER ONLY
 UPDATED: 10/29/2014

W1

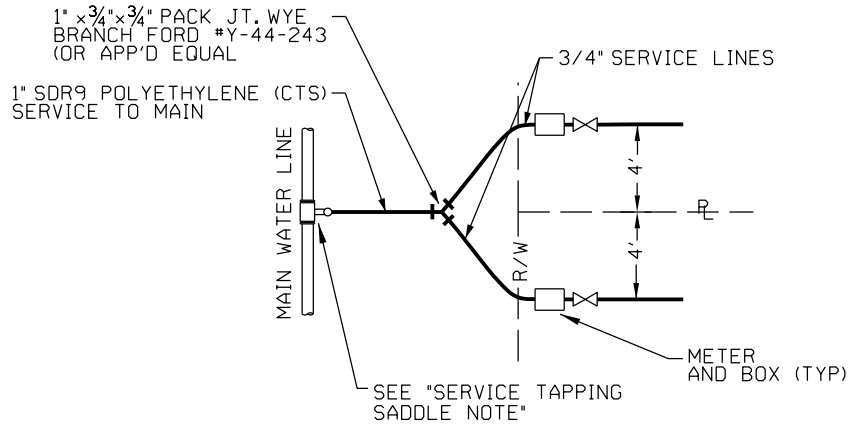

SERVICE TAPPING SADDLE NOTE:
 SMITH-BLAIR SINGLE STRAP, NYLON-COATED WITH
 WIDE SST BANDS NO. 315; OR SMITH-BLAIR DOUBLE STRAP,
 NYLON-COATED WITH WIDE SST BANDS NO. 317.

PLAN

TYPICAL DOUBLE SERVICE CONNECTION

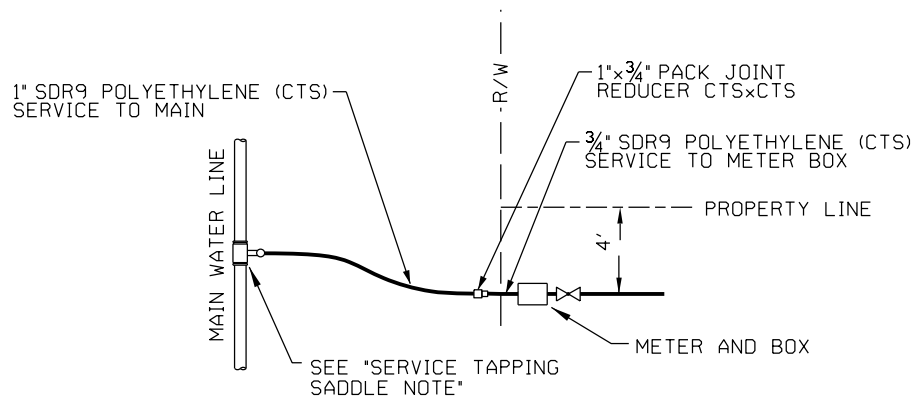

SERVICE TAPPING SADDLE NOTE:
 SMITH-BLAIR SINGLE STRAP, NYLON-COATED WITH
 WIDE SST BANDS NO. 315; OR SMITH-BLAIR DOUBLE STRAP,
 NYLON-COATED WITH WIDE SST BANDS NO. 317.

PLAN

TYPICAL SINGLE SERVICE CONNECTION

W3

TYPICAL WATER SERVICE DETAIL
 FOR FUTURE CUSTOMER CONNECTIONS
 (FOR GSWA RURAL & CAPITAL
 PROJECTS ONLY)

WATER ONLY
 UPDATED: 06/19/09

W3

LATEST REVISION:
 06/19/09 DRT CHANGED TEE TO WYE, ADDED PACK JOINT
 REDUCER AND REVISED SIZES.

GRAND STRAND
 WATER & SEWER AUTHORITY

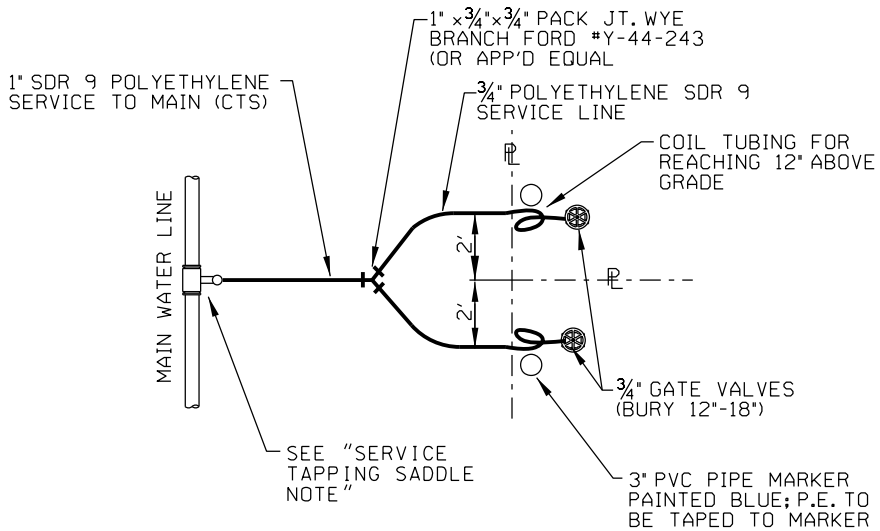

SERVICE TAPPING SADDLE NOTE:
 SMITH-BLAIR SINGLE STRAP, NYLON-COATED WITH
 WIDE SST BANDS NO. 315; OR SMITH-BLAIR DOUBLE STRAP,
 NYLON-COATED WITH WIDE SST BANDS NO. 317.

PLAN

TYPICAL DOUBLE SERVICE CONNECTION
 FOR FUTURE CUSTOMER CONNECTIONS
 (FOR DEVELOPER PROJECTS ONLY)

W4

TYPICAL DOUBLE SERVICE CONNECTION FOR FUTURE CUSTOMER CONNECTIONS (FOR DEVELOPER PROJECTS ONLY)	
WATER ONLY UPDATED: 6/26/02	W4
GRAND STRAND WATER & SEWER AUTHORITY	

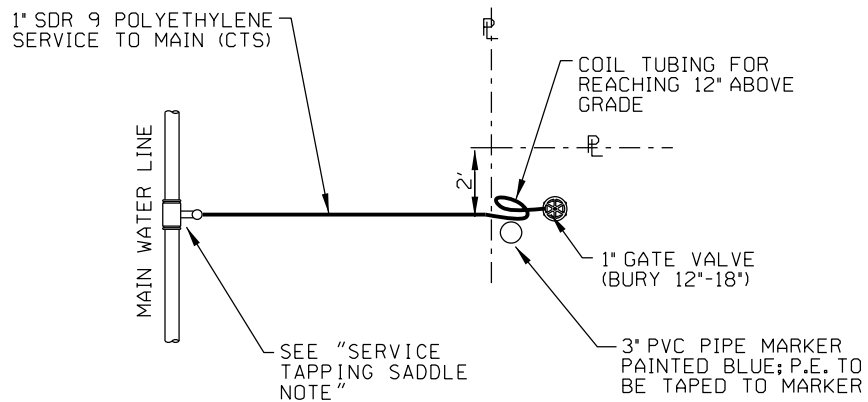

SERVICE TAPPING SADDLE NOTE:
 SMITH-BLAIR SINGLE STRAP, NYLON-COATED WITH
 WIDE SST BANDS NO. 315; OR SMITH-BLAIR DOUBLE STRAP,
 NYLON-COATED WITH WIDE SST BANDS NO. 317.

PLAN

TYPICAL SINGLE SERVICE CONNECTION
FOR FUTURE CUSTOMER CONNECTIONS
(FOR DEVELOPER PROJECTS ONLY)

W5

TYPICAL SINGLE SERVICE CONNECTION FOR FUTURE CUSTOMER CONNECTIONS (FOR DEVELOPER PROJECTS ONLY)	
WATER ONLY UPDATED: 6/26/02	<div style="border: 1px solid black; padding: 2px; width: 30px; height: 30px; margin: 0 auto;">W5</div>
GRAND STRAND WATER & SEWER AUTHORITY	

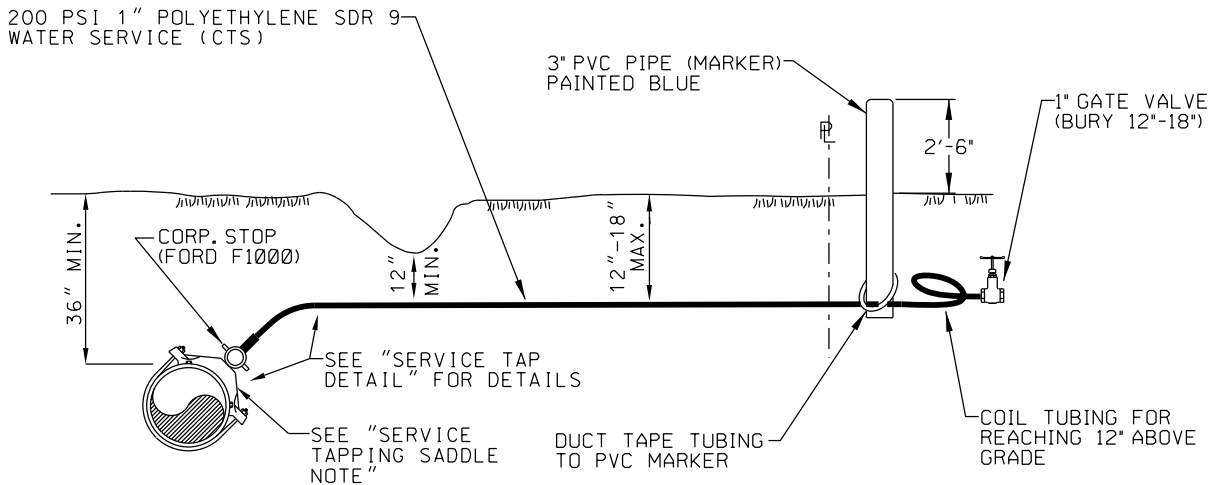

SERVICE TAPPING SADDLE NOTE:
 SMITH-BLAIR SINGLE STRAP, NYLON-COATED WITH
 WIDE SST BANDS NO. 315; OR SMITH-BLAIR DOUBLE STRAP,
 NYLON-COATED WITH WIDE SST BANDS NO. 317.

TYPICAL WATER SERVICE DETAIL
FOR FUTURE CUSTOMER CONNECTIONS
(FOR DEVELOPER PROJECTS ONLY)

W6

TYPICAL WATER SERVICE DETAIL FOR FUTURE CUSTOMER CONNECTIONS (FOR DEVELOPER PROJECTS ONLY)	
WATER ONLY UPDATED: 6/26/02	W6
GRAND STRAND WATER & SEWER AUTHORITY	

SERVICE LINE (CTS):
 TYP. 200 PSI POLYETHYLENE
 SDR 9 SERVICE MAT'L. PER
 AWWA STDS. COMPRESSION
 FITTING USE 1" FOR SINGLE
 AND DOUBLE METER SERVICES.

CORPORATION STOP
 FORD F1000 W/COMPRESSION
 FITTING OR APPR. EQUAL

WATER MAIN

RUBBER GASKET

45° MIN.

SEE "SERVICE
 TAPPING SADDLE
 NOTE"

SERVICE TAPPING SADDLE NOTE:
 SMITH-BLAIR SINGLE STRAP, NYLON-COATED WITH
 WIDE SST BANDS NO. 315; OR SMITH-BLAIR DOUBLE STRAP,
 NYLON-COATED WITH WIDE SST BANDS NO. 317.

TYPICAL SERVICE TAP

W7

TYPICAL SERVICE TAP

WATER ONLY
 UPDATED: 08/28/06

W7

GRAND STRAND
 WATER & SEWER AUTHORITY

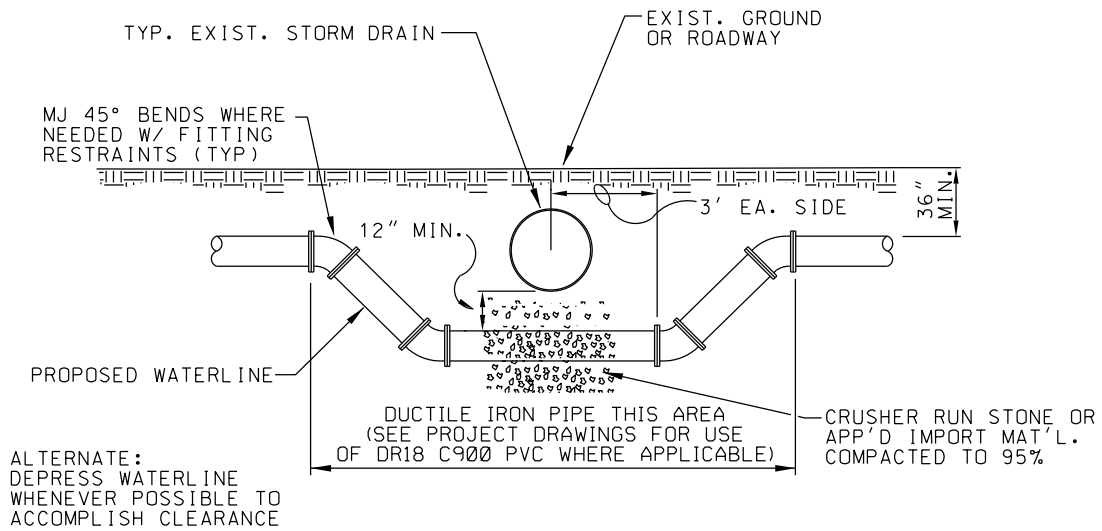

TYPICAL STORM DRAIN CROSSING

W8

TYPICAL STORM DRAIN CROSSING

WATER ONLY
 UPDATED: 5/13/02

W8

GRAND STRAND
 WATER & SEWER AUTHORITY

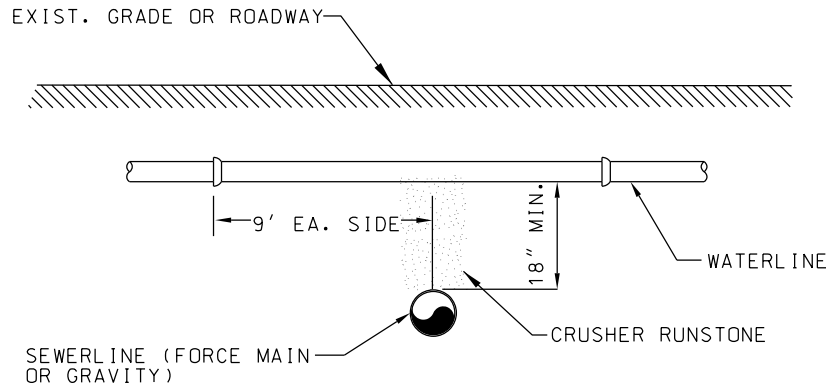

TYPICAL SEWERLINE CROSSING

W9

TYPICAL SEWERLINE CROSSING

WATER ONLY
UPDATED: 2/16/98

W9

GRAND STRAND
WATER & SEWER AUTHORITY

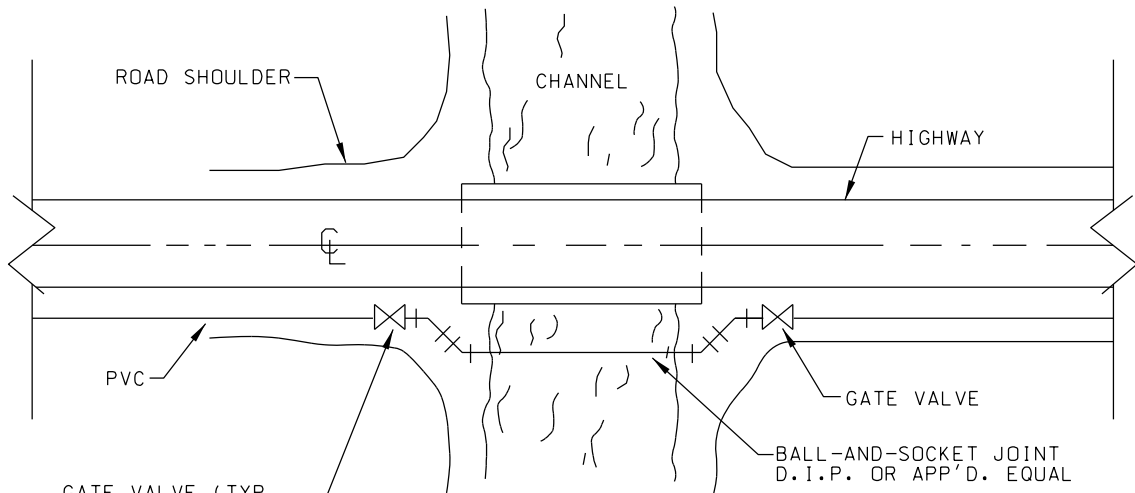

PLAN

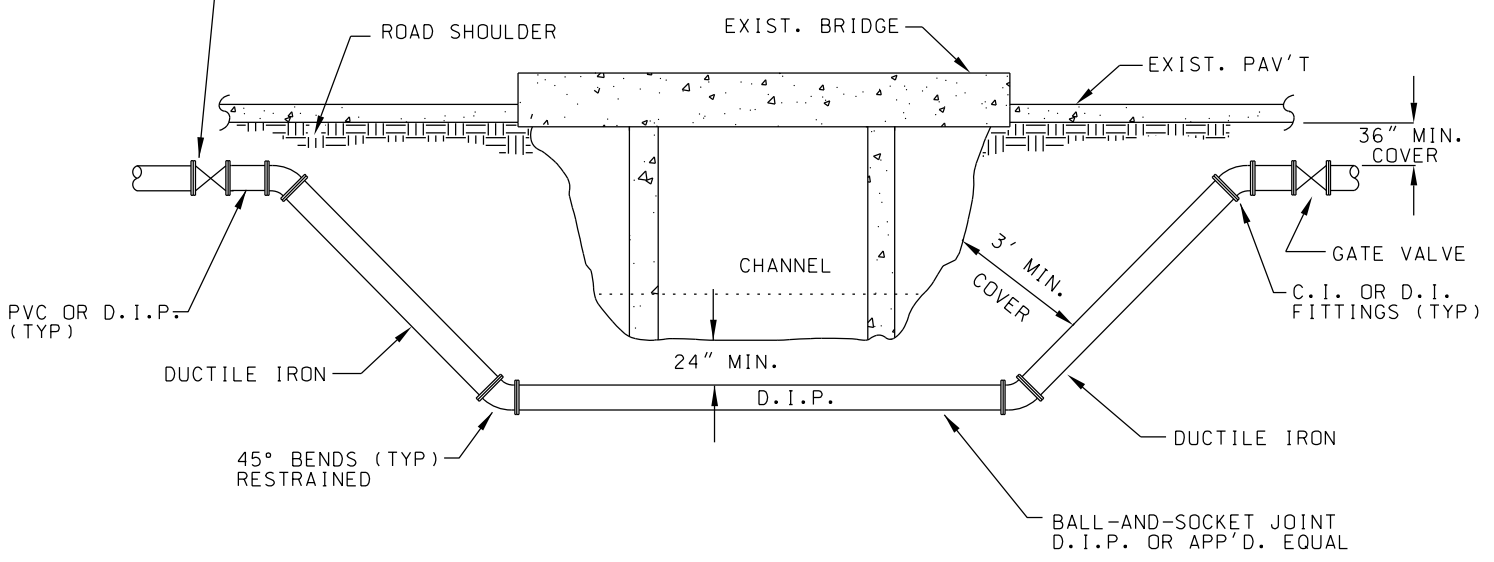

PROFILE

NOTE:
PIPE TO BE INSTALLED IN SUCH
A MANNER THAT JOINTS WILL BE
ON UNDISTURBED SOIL.

NOTES:
1) ALL JOINTS TO BE RESTRAINED.
2) FOR CROSSING WATER COURSES
GREATER THAN FIFTEEN (15) FEET
IN WIDTH, A BLOWOFF SHALL BE
PROVIDED ON THE SIDE OPPOSITE
THE SUPPLY SERVICE IF SYSTEM
IS NOT LOOPED.

TYPICAL UNDER CHANNEL CROSSING AT BRIDGE

W10

TYPICAL UNDER CHANNEL CROSSING AT BRIDGE	
WATER ONLY UPDATED: 12/26/97	
W10	
GRAND STRAND WATER & SEWER AUTHORITY	

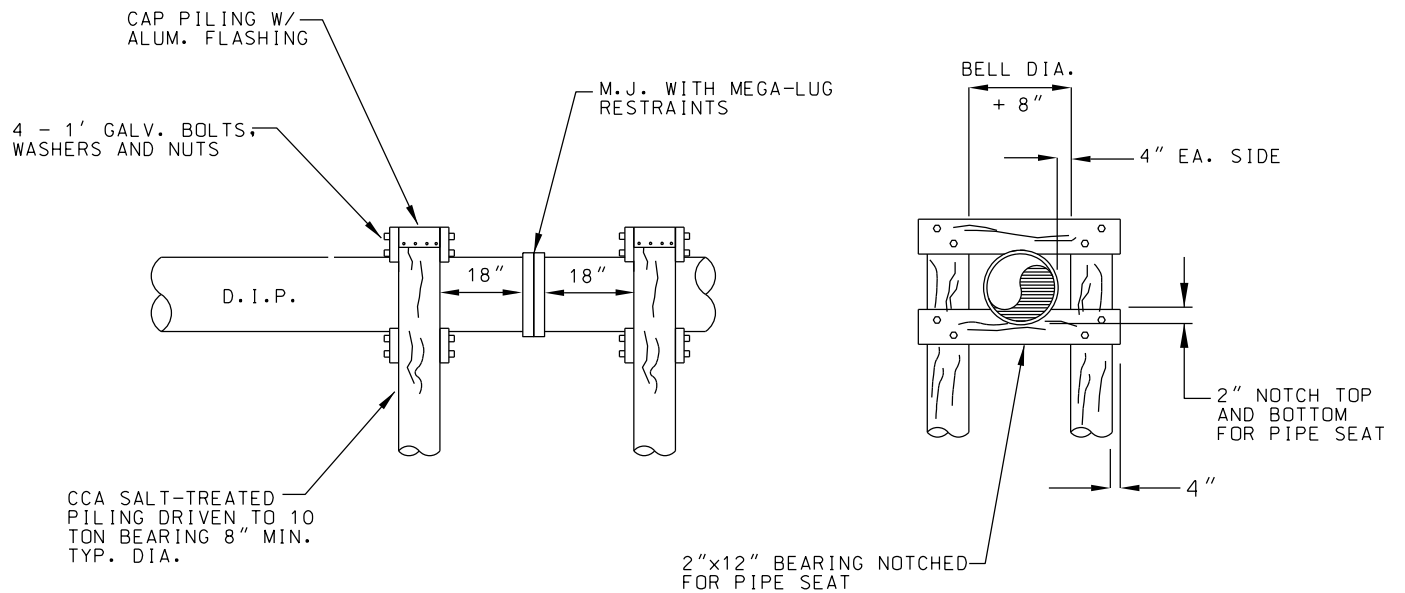

TYPICAL SUPPORT PILING

NOTE: GSWA TO APPROVE CONTRACTORS PROPOSED
LOCATION OF PILE FRAMES PRIOR TO INSTALLATION

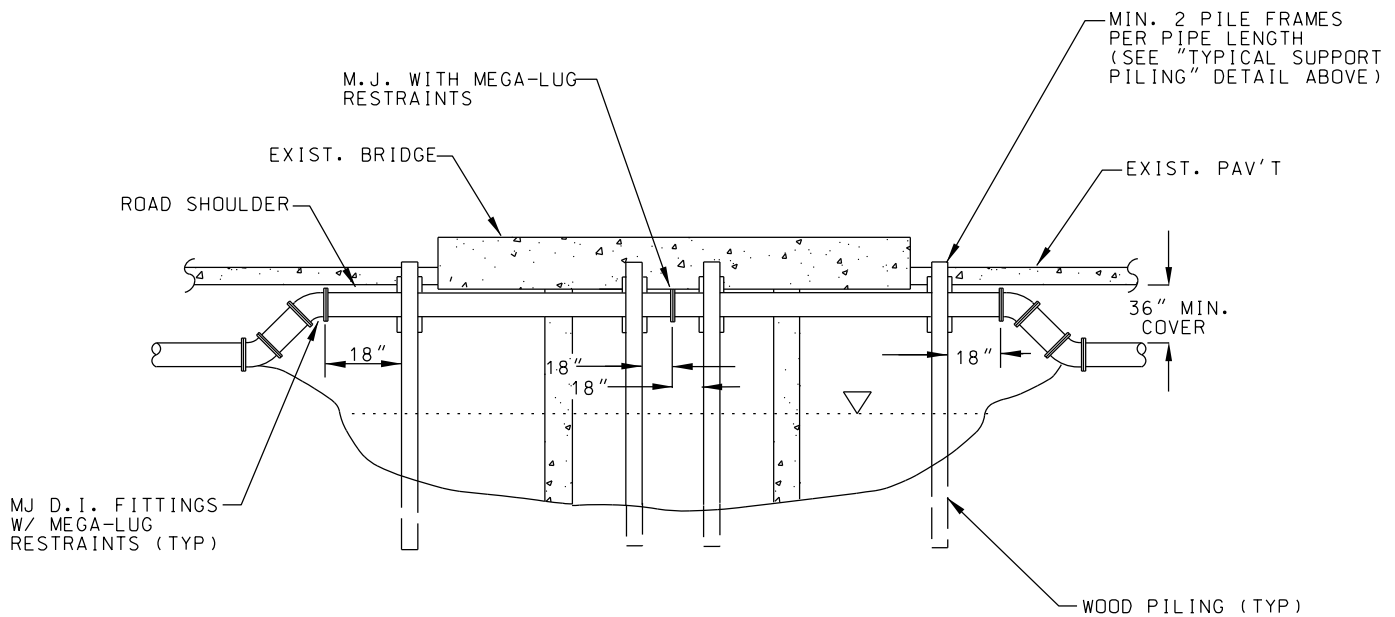

TYPICAL ABOVE CHANNEL CROSSING AT BRIDGE

W11

TYPICAL
ABOVE CHANNEL
CROSSING AT BRIDGE

WATER ONLY
UPDATED: 12/26/97

W11

GRAND STRAND
WATER & SEWER AUTHORITY

ENCLOSURE BOX AND LID SHALL BE
 MINIMUM "TIER 22" LOAD RATING:
 VERTICAL: 22,500 LBS (DESIGN) / 33,750 LBS (TEST)
 LATERAL: 800 LBS/SF (DESIGN) / 1,200 LBS/SF (TEST)
 (DRIVEWAY, PARKING LOT, AND OFF-ROADWAY APPLICATIONS
 SUBJECT TO OCCASIONAL NON-DELIBERATE HEAVY
 VEHICULAR TRAFFIC)

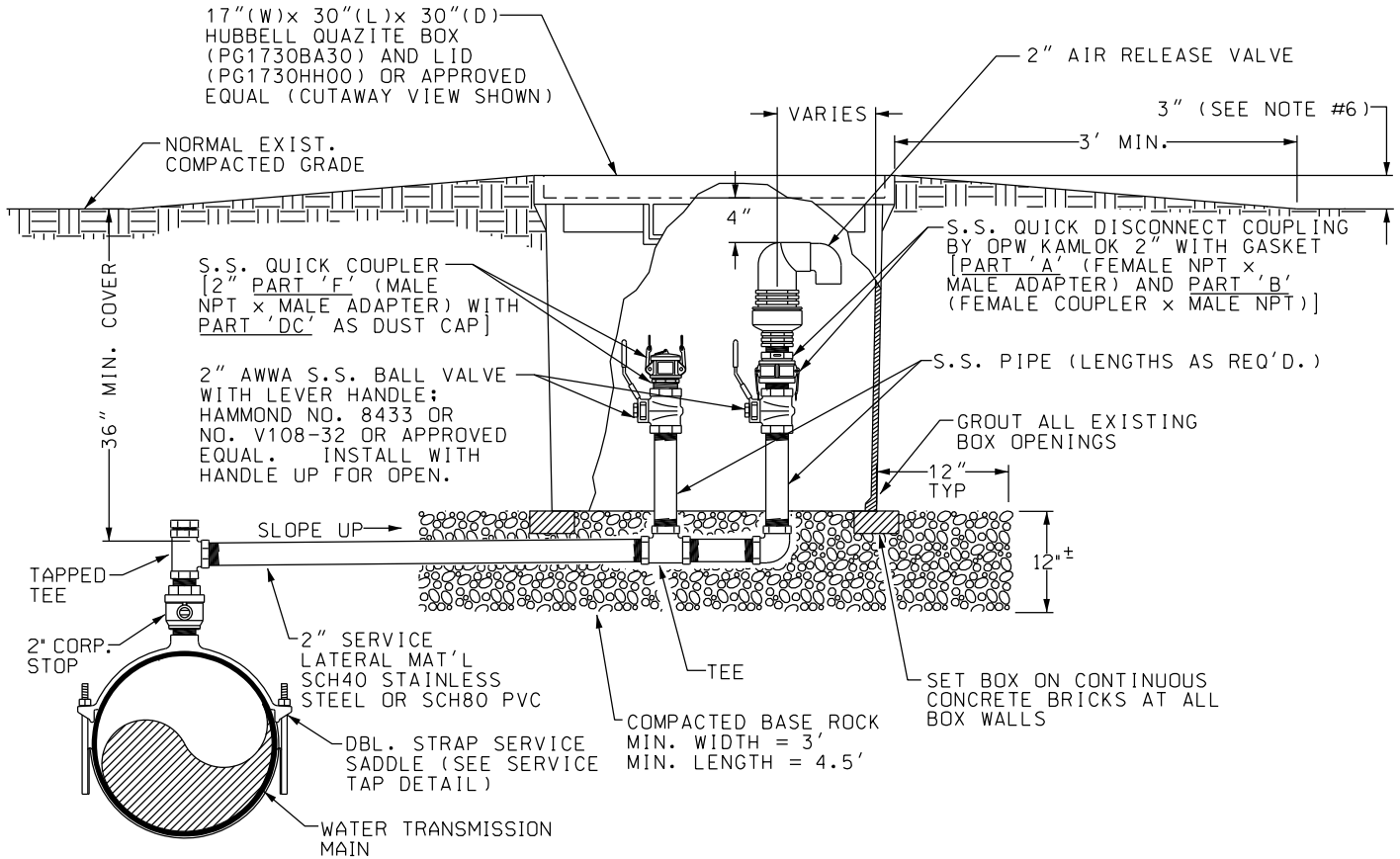

NOTES:

- 1) AIR RELEASE VALVE SHALL BE INSTALLED ON THE HIGH POINT OF WATER MAIN.
- 2) ALL MATERIALS & EQUIPMENT TO BE PER AWWA SPEC'S.
- 3) AIR RELEASE SHALL BE VALMATIC NO. 38, A.R.I. MODEL D-040.2 OR APPROVED EQUAL
- 4) CORP. STOP, PIPING, FITTINGS, AND VALVES TO BE SAME DIAMETER AS AIR RELEASE VALVE INLET.
- 5) LIMIT OF PAY ITEMS INCLUDES SERVICE SADDLE.
- 6) ARV ASSEMBLIES INSTALLED IN ROAD RIGHTS-OF-WAY MUST BE FLUSH WITH EXISTING SHOULDER GRADE. INSTALLATIONS IN EASEMENT AREAS SHALL BE RAISED ABOVE EXISTING GRADE AS SHOWN IN DETAIL.
- 7) 2" TEE, NIPPLE & BALL VALVE TO BE STD AWWA OR APPROVED EQUAL. NIPPLES & BALL VALVES SHALL BE STAINLESS STEEL.

TYPICAL AIR RELEASE VALVE ASSEMBLY

W12

LATEST REVISION:
 07/18/08 DRT

DESCRIBED PARTS 'A' & 'B' FOR A.R.V. QUICK DISCONNECT AND CHANGED PART 'A' TO PART 'F' FOR OTHER QUICK DISCONNECT. REMOVED NOTE FOR STABILITY BLOCKING INSIDE BOX. CHANGED ENCLOSURE SUPPLIER FROM STRONGWELL TO HUBBELL.

12/02/2013 DRT CHANGED LID TO "HH" (TIER 22) AND ADDED NOTE FOR TIER 22 ENCLOSURE BOX AND LID.

TYPICAL AIR RELEASE VALVE ASSEMBLY

WATER ONLY
 UPDATED: 12/02/2013

W12

GRAND STRAND
 WATER & SEWER AUTHORITY

ENCLOSURE BOX AND LID SHALL BE
 MINIMUM "TIER 22" LOAD RATING:
 VERTICAL: 22,500 LBS (DESIGN) / 33,750 LBS (TEST)
 LATERAL: 800 LBS/SF (DESIGN) / 1,200 LBS/SF (TEST)
 (DRIVEWAY, PARKING LOT, AND OFF-ROADWAY APPLICATIONS
 SUBJECT TO OCCASIONAL NON-DELIBERATE HEAVY
 VEHICULAR TRAFFIC)

17"(W)x 30"(L)x 30"(D)
 HUBBELL QUAZITE BOX
 (PG1730BA30) AND LID
 (PG1730HH00) OR APPROVED
 EQUAL (CUTAWAY VIEW SHOWN)

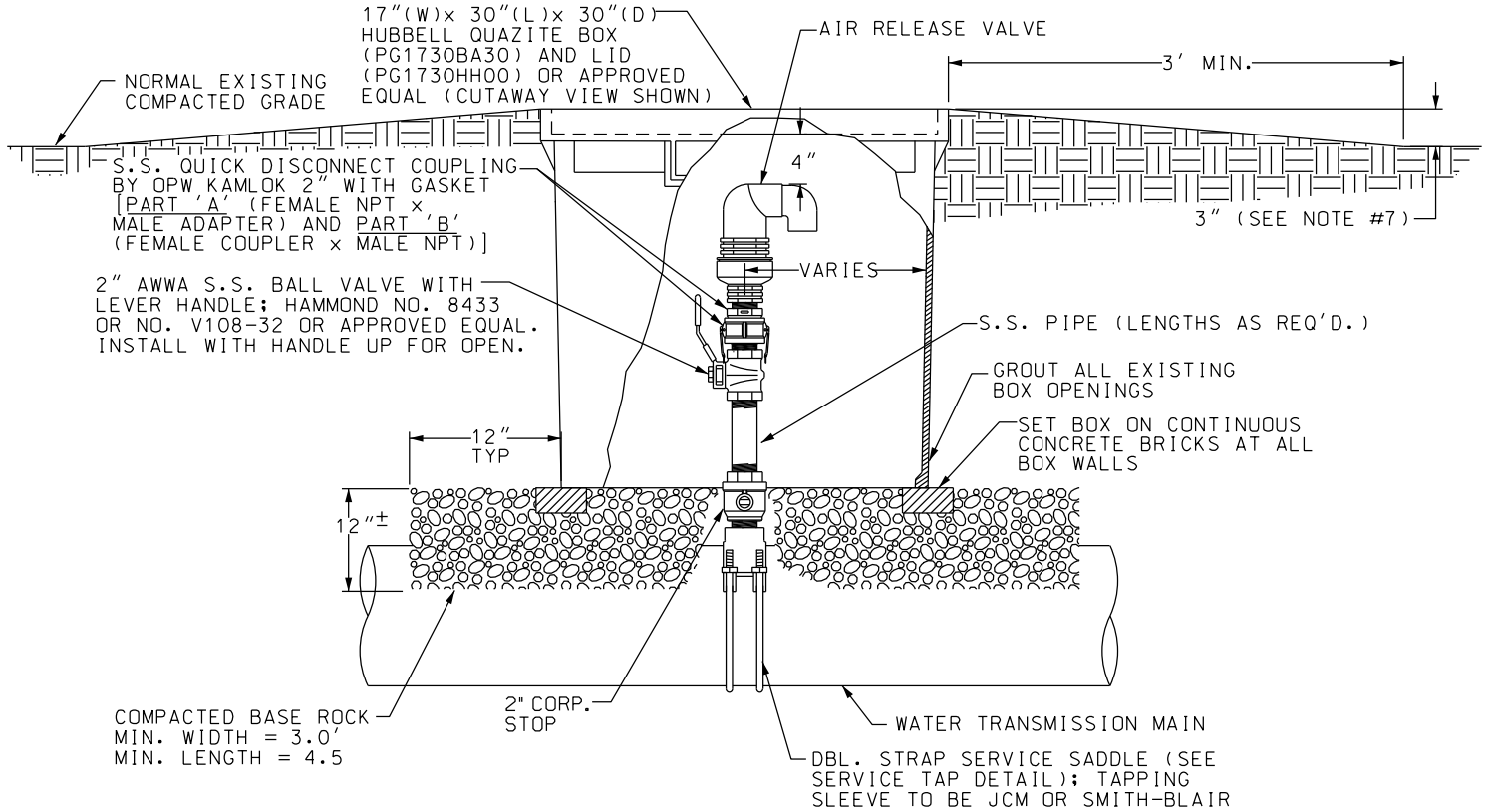

NOTES:

- 1) AIR RELEASE VALVE SHALL BE INSTALLED ON THE HIGH POINT OF WATER MAIN.
- 2) ALL MATERIALS & EQUIPMENT TO BE PER AWWA SPEC'S.
- 3) AIR RELEASE SHALL BE A.R.I. MODEL D-040.2.
- 4) CORPORATION STOP, S.S. PIPE, FITTINGS, AND PIPING TO BE SAME DIAMETER AS AIR RELEASE VALVE INLET.
- 5) AIR RELEASE VALVES MUST BE NSF APPROVED.
- 6) LIMIT OF PAY ITEMS INCLUDES SERVICE SADDLE.
- 7) ARV ASSEMBLIES INSTALLED IN ROAD RIGHTS-OF-WAY MUST BE FLUSH WITH EXISTING SHOULDER GRADE. INSTALLATIONS IN EASEMENT AREAS SHALL BE RAISED ABOVE EXISTING GRADE AS SHOWN IN DETAIL.

TYPICAL AIR RELEASE VALVE ASSEMBLY

W13

LATEST REVISION:
 07/18/08 DRT

12/02/2013 DRT

DESCRIBED PARTS 'A' & 'B' FOR QUICK DISCONNECT.
 REMOVED NOTE FOR STABILITY BLOCKING INSIDE BOX.
 CHANGED ENCLOSURE SUPPLIER FROM STRONGWELL TO HUBBELL.
 CHANGED LID TO "HH" (TIER 22) AND ADDED NOTE FOR
 TIER 22 ENCLOSURE BOX AND LID.

**TYPICAL
 AIR RELEASE VALVE
 ASSEMBLY**

WATER ONLY
 UPDATED: 12/02/2013

W13

GRAND STRAND
 WATER & SEWER AUTHORITY

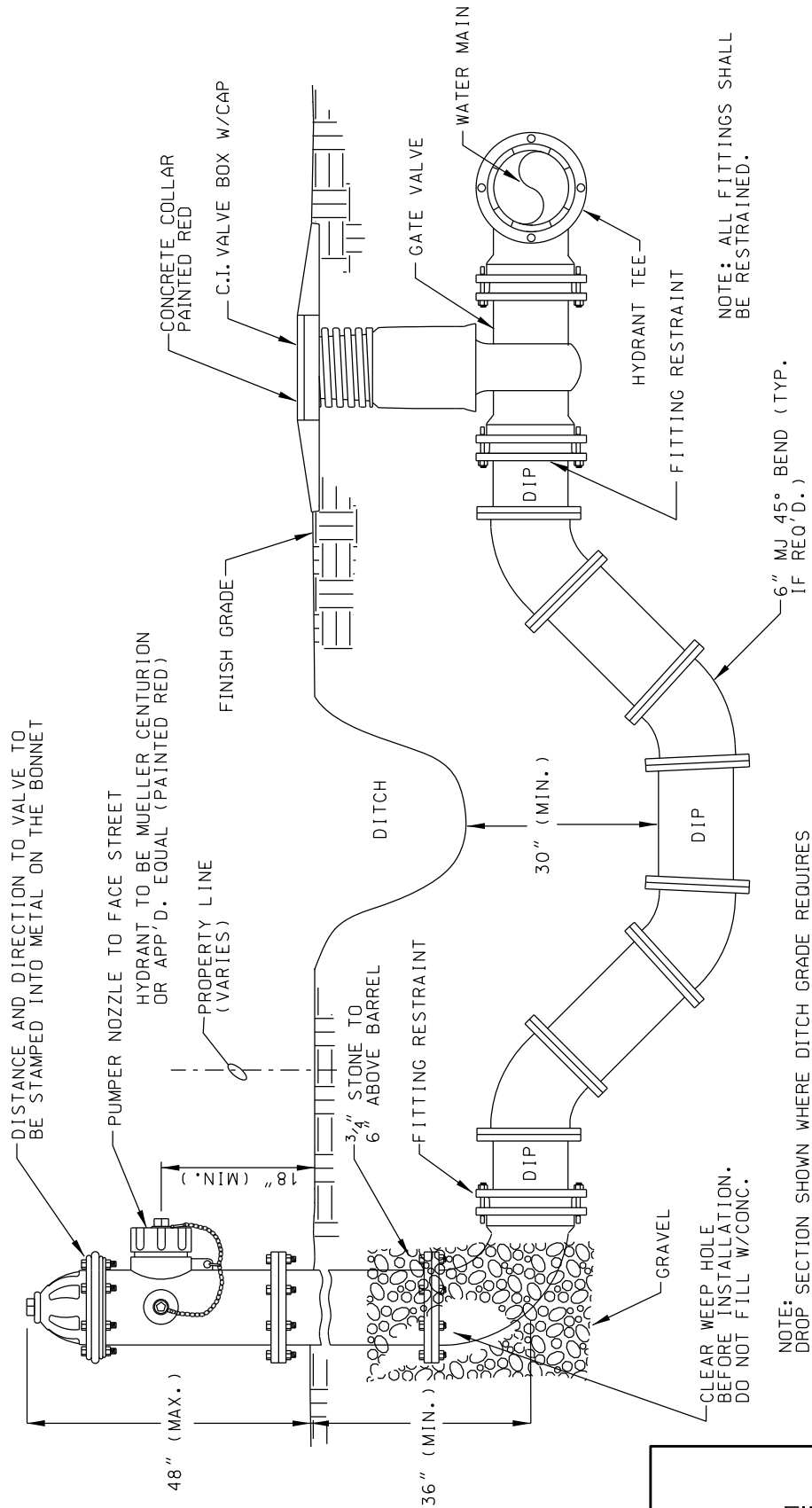

TYPICAL FIRE HYDRANT

W14

TYPICAL FIRE HYDRANT	
WATER ONLY UPDATED: 8/13/01	
W14	
GRAND STRAND WATER & SEWER AUTHORITY	

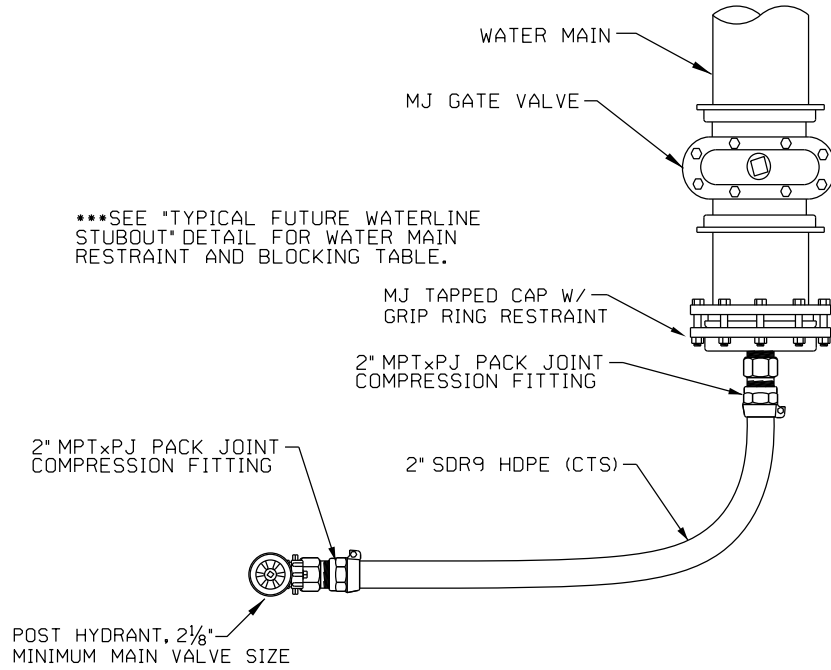

PLAN

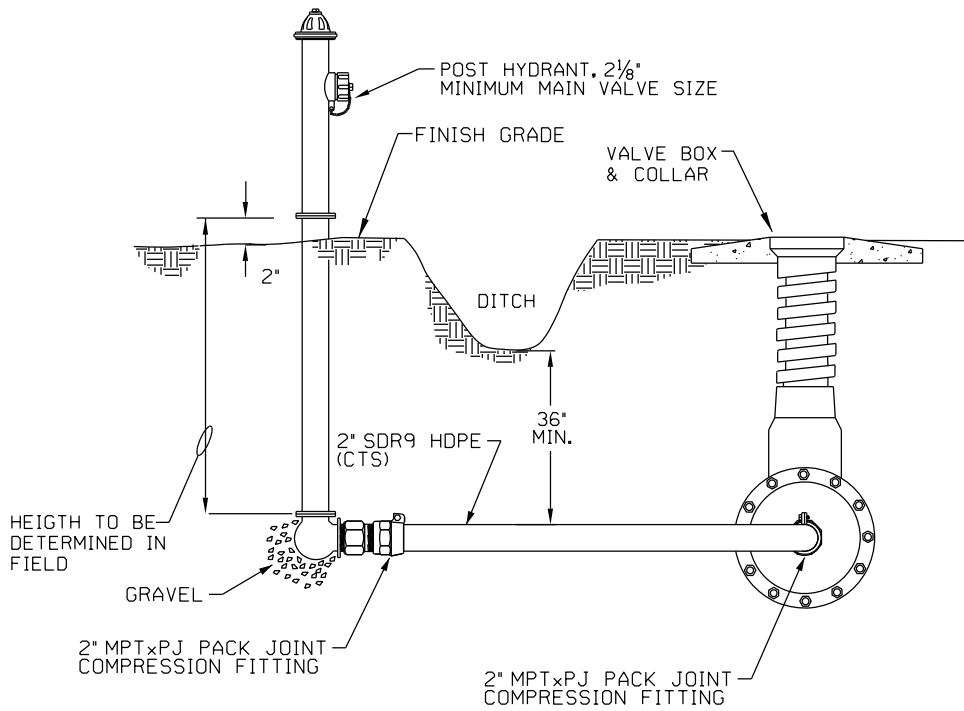

PROFILE

TYPICAL POST HYDRANT BLOW-OFF

W15

TYPICAL POST HYDRANT BLOW-OFF

WATER ONLY
 UPDATED: 06/19/09

W15

GRAND STRAND
 WATER & SEWER AUTHORITY

LATEST REVISION:
 06/19/09 DRT CHANGED PH LEAD FROM GIP TO HDPE AND ADDED
 PACK JOINT FITTINGS.

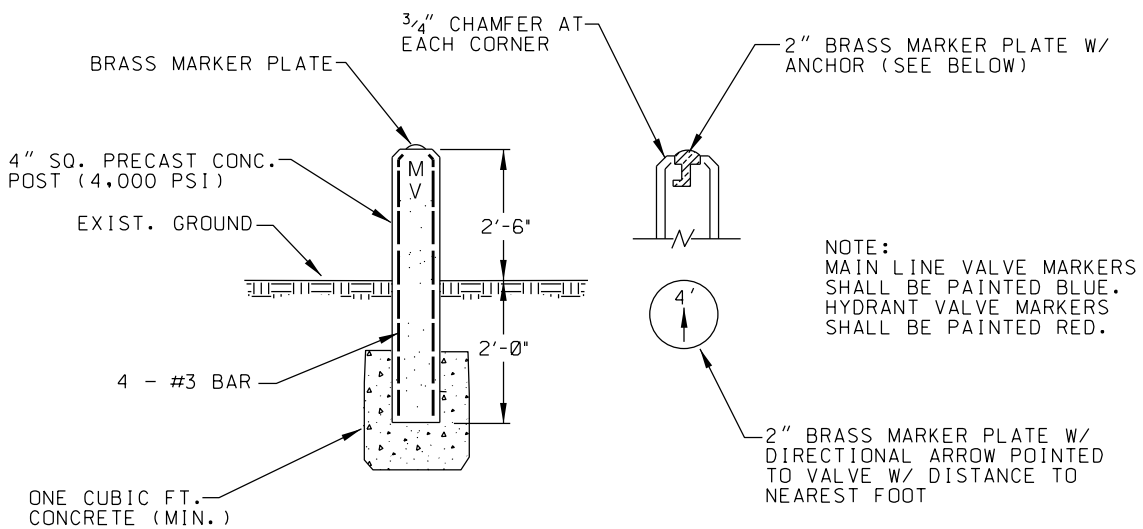

TYPICAL CONCRETE VALVE MARKER

W17

TYPICAL
CONCRETE VALVE MARKER

WATER ONLY
UPDATED: 5/13/02

W17

GRAND STRAND
WATER & SEWER AUTHORITY

ENCLOSURE BOX AND LID SHALL BE
 MINIMUM "TIER 22" LOAD RATING:
 VERTICAL: 22,500 LBS (DESIGN) / 33,750 LBS (TEST)
 LATERAL: 800 LBS/SF (DESIGN) / 1,200 LBS/SF (TEST)
 (DRIVEWAY, PARKING LOT, AND OFF-ROADWAY APPLICATIONS
 SUBJECT TO OCCASIONAL NON-DELIBERATE HEAVY
 VEHICULAR TRAFFIC)

17"(W) x 30"(L) x 18"(D)
 HUBBELL QUAZITE BOX
 (PG1730BA18) AND LID
 (PG1730HH00) OR APPROVED
 EQUAL (CUTAWAY VIEW SHOWN)

SHOWN PREASSEMBLED

S.S. QUICK COUPLER
 [1 1/2" PART 'F' (MALE
 NPT x MALE ADAPTER) WITH
 PART 'DC' AS DUST CAP]

VALVE BOX COLLAR

GRADE

1 1/2" AWWA S.S. BALL
 VALVE WITH LEVER HANDLE;
 HAMMOND NO. 8433 OR
 NO. V108-32 OR APPROVED
 EQUAL. INSTALL WITH
 HANDLE UP FOR OPEN.

THRUST BLOCKING

VALVE BOX

1 1/2" HDPE 3408
 PIPE (INCLUDE
 FITTINGS NEEDED
 FOR CONNECTION
 TO TAPPED PLUG
 AND BLOWOFF)

1 1/2" S.S. NIPPLE (TYP)
 OF VARIOUS LENGTHS

1 1/2" 90° BEND

4" MJ GATE
 VALVE

ADJUST SIZE CHANGE
 AT THIS LOCATION

SEE TABLE FOR
 RECOMMENDED SIZE

PIPE CONFIGURATION TO BLOWOFF
 TO BE FIELD-DETERMINED (CURVE
 PIPE TO KEEP FROM CRIMPING.)

NOTE:
 THIS DETAIL IS FOR MAIN LINES 4" DIA. AND SMALLER.
 BLOWOFFS SHALL BE SIZED TO ACHIEVE 2.5 FT/SEC
 MINIMUM VELOCITY IN THE MAIN WITH A MINIMUM
 RESIDUAL PRESSURE OF 25 PSI. THE TABLE BELOW
 IS RECOMMENDED BY THE SC DHEC FOR BLOWOFF SIZING.
 USE STANDARD POST HYDRANT BLOWOFF FOR MAINS
 LARGER THAN 4' DIA..

4" x 1 1/2" MJ TAPPED
 PLUG (RESTRAINED)

4" MAIN
 WATERLINE

MAIN LINE DIA.	FLOW REQUIRED	MIN. ORIFICE SIZE	RECOMMENDED PIPE SIZE	RECOMMENDED BLOWOFF SIZE
2"	25 GPM	0.75"	1 1/2"	1 1/2"
2 1/2"	40 GPM	1"	1 1/2"	1 1/2"
3"	60 GPM	1.24"	1 1/2"	1 1/2"
4"	100 GPM	1.5"	1 1/2"	1 1/2"
*6"	220 GPM	1.65"	2"	2"
*8"	400 GPM	2.21"	2 1/2"	2 1/2"

*SEE "TYPICAL POST HYDRANT BLOWOFF" (W15) FOR DETAIL.

TYPICAL BLOWOFF ASSEMBLY

W18

TYPICAL BLOWOFF ASSEMBLY

WATER ONLY
 UPDATED: 12/02/2013

W18

GRAND STRAND
 WATER & SEWER AUTHORITY

LATEST REVISION:
 7/18/08 DRT CHANGED PART 'A' TO PART 'F' FOR QUICK COUPLER.
 CHANGED ENCLOSURE SUPPLIER FROM STRONGWELL TO HUBBELL.
 12/02/2013 DRT ADDED NOTE FOR TIER 22 ENCLOSURE BOX AND LID.

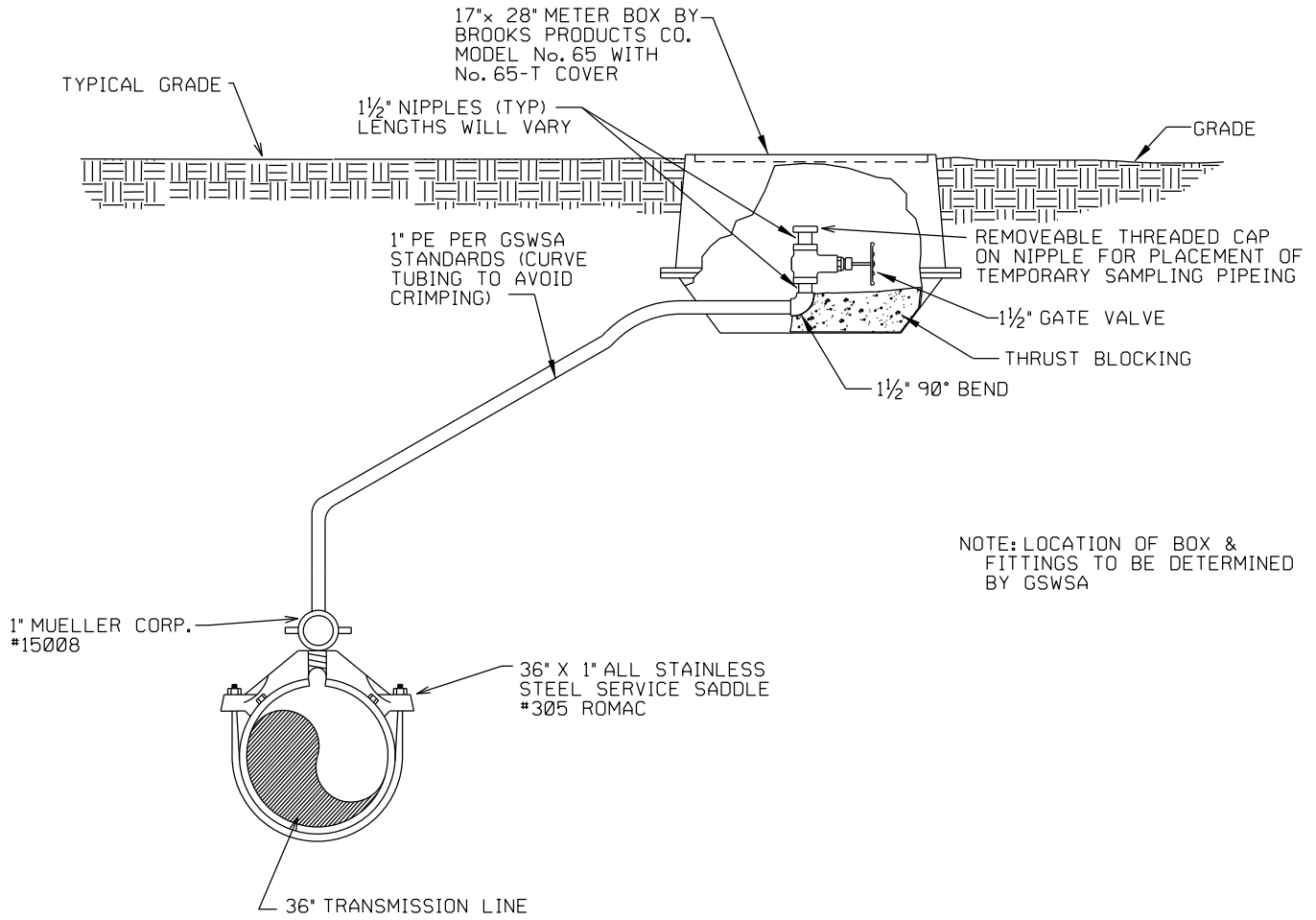

TYPICAL WATER SAMPLING ASSEMBLY

W19

TYPICAL WATER SAMPLING ASSEMBLY

WATER ONLY
UPDATED: 5/24/99

W19

GRAND STRAND
WATER & SEWER AUTHORITY

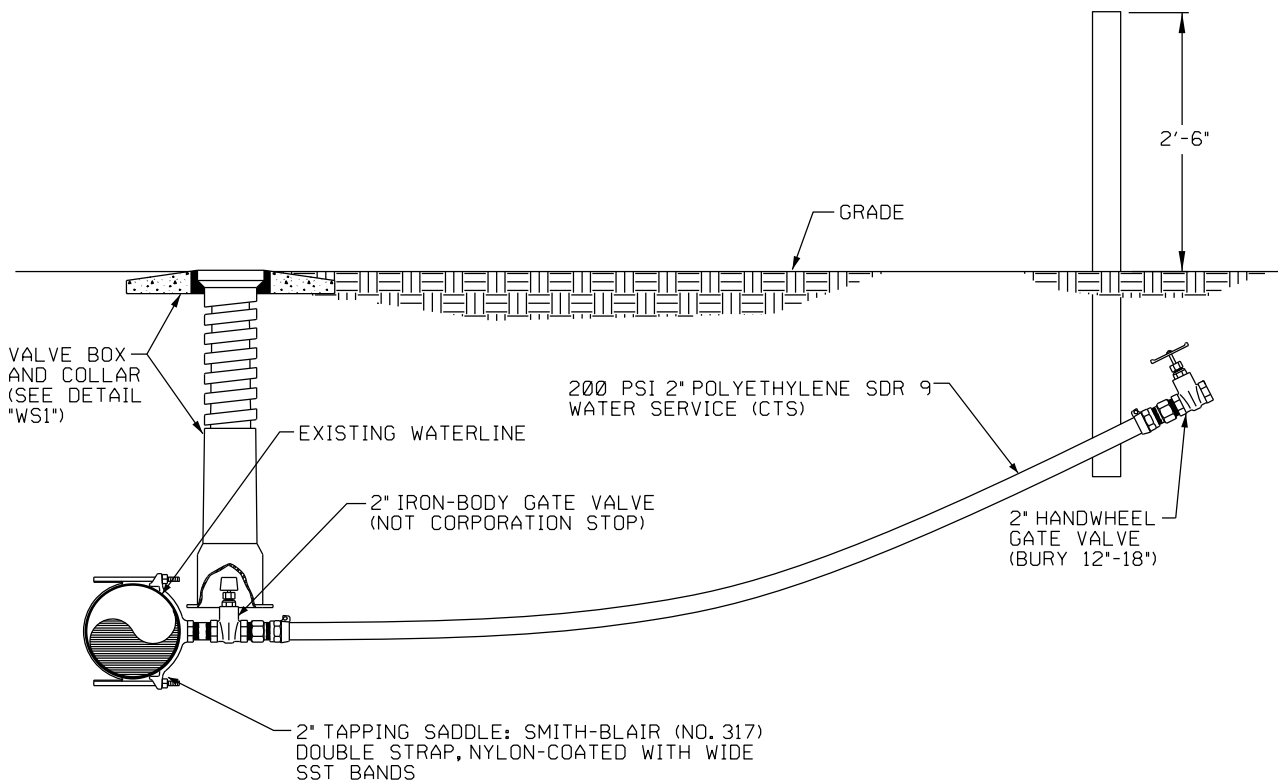

ELEVATION

TYPICAL WATER SERVICE DETAIL
FOR 1 1/2" – 2" METER SERVICES
(FOR DEVELOPER PROJECTS ONLY)

W20

TYPICAL WATER SERVICE DETAIL
 FOR 1 1/2" – 2" METER SERVICES
 (FOR DEVELOPER PROJECTS ONLY)

WATER ONLY
 UPDATED: 02/02/2010

W20

GRAND STRAND
 WATER & SEWER AUTHORITY

LATEST REVISION:
 02/02/2010 DRT 2" HANDWHEEL G.V. TO BE BURIED RATHER
 THAN LEFT ABOVE GROUND.

DCDA SIZE	A	B	C	D*	ENCLOSURE MODEL
3"	29 1/8"	25 3/4"	3 3/4"	22 1/4"	45N
4"	31 1/8"	27 3/4"	4 1/2"	23 1/4"	
6"	35 3/4"	32 3/4"	5 1/2"	30 1/8"	
8"	40 3/4"	36 3/4"	6 3/4"	37 3/4"	56N

*INDICATES NOMINAL DIMENSIONS WITH OSY GATE VALVE (FULL OPEN POSITION)

ENCLOSURE MODEL	E	F	G	H	I	J	K	L
45N	48"	50"	45"	49"	42"	45"	33"	14"
56N	60"	62"	56"	60"	56"	60"	39"	12"

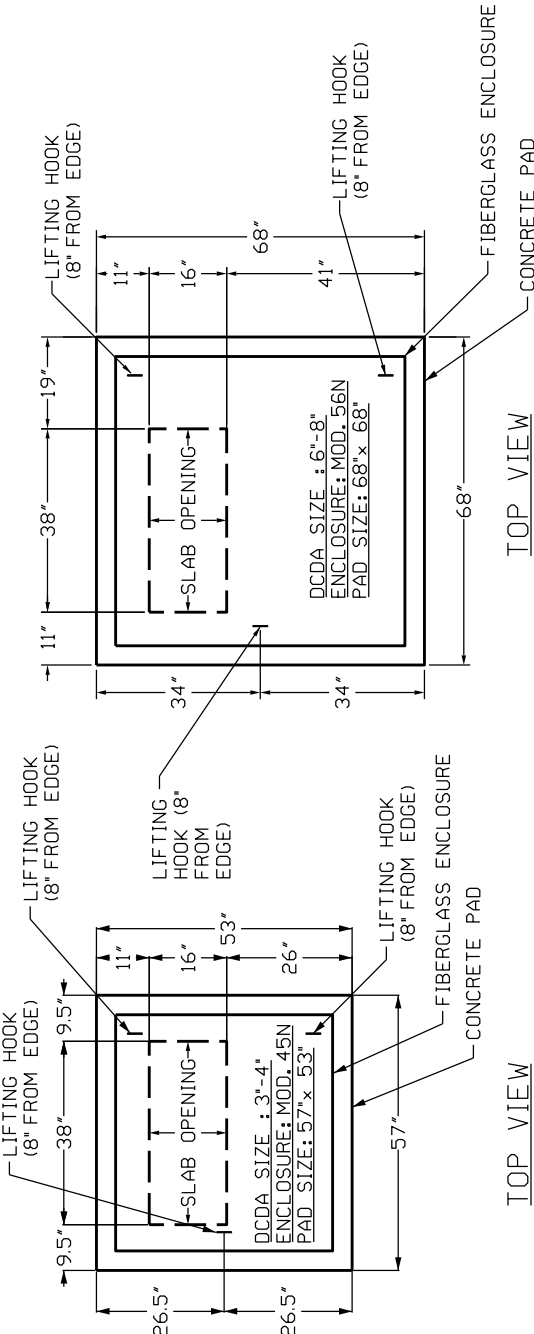

TOP VIEW

TOP VIEW

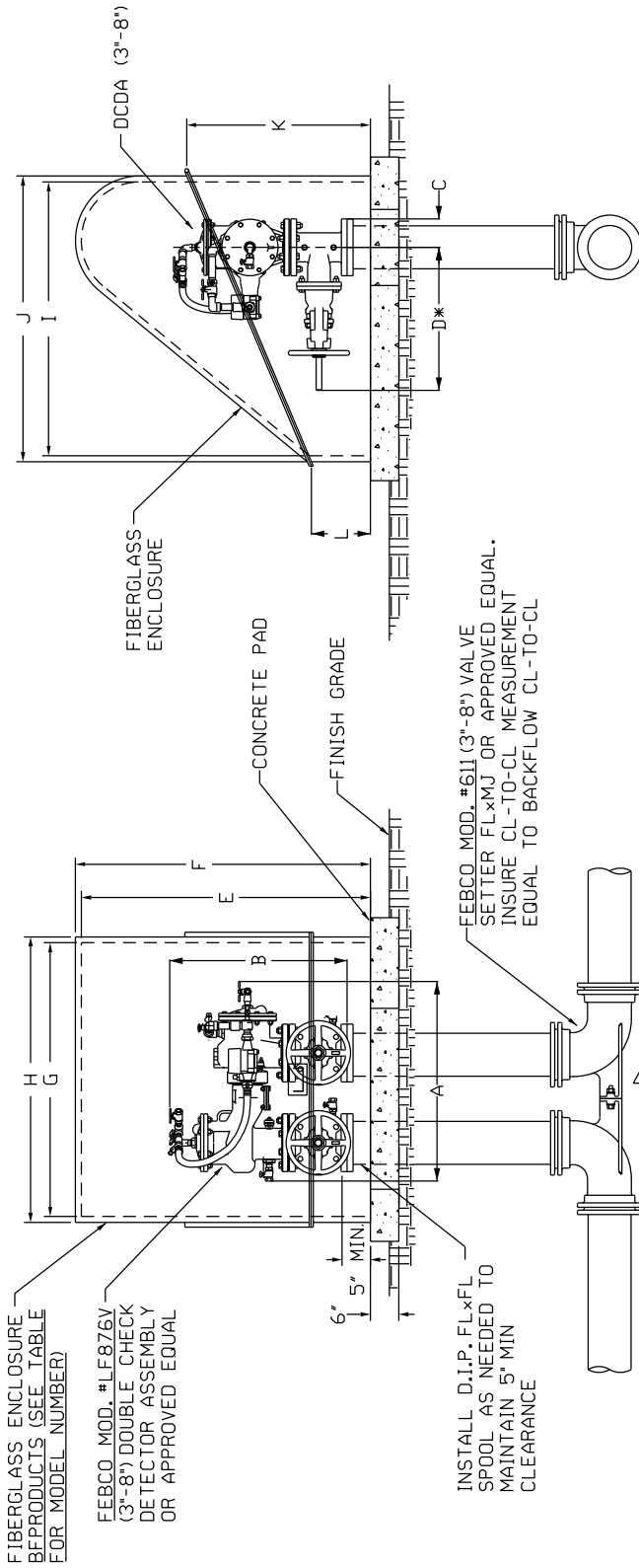

TYPICAL DOUBLE CHECK DETECTOR ASSEMBLY (4"-8") ABOVE GROUND MOUNT WITH ENCLOSURE

WATER ONLY
UPDATED: 10/16/2015

W22

GRAND STRAND
WATER & SEWER AUTHORITY

TYPICAL DOUBLE CHECK DETECTOR ASSEMBLY (3"-8") ABOVE GROUND MOUNT WITH ENCLOSURE